

AMF



Product Orientor Loader Upgrade Kits



- ▼ ***Substantially improve the performance of your existing AMF or Pulver Product Orientor Loader with performance enhancing upgrade kits.***
- ▼ ***These kits will upgrade your loaders to the latest designs used on new AMF Product Orientor Loaders at a fraction of the cost of replacement.***
- ▼ ***Upgrades available for the Window Belt, Disc Turner, Pusher, Operator Interface & PLC.***

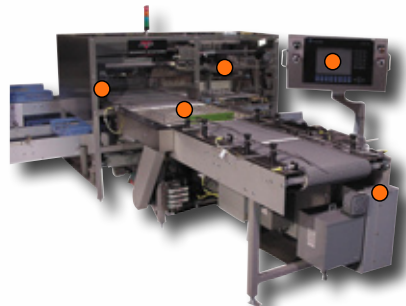

Servo Driven Window Belt Servo Upgrade

Window Belt Upgrade

- Replace the clutch/brake drive with a servo drive with programmable accel and decel curves for smoother, more accurate control of product resulting in less damaged or crippled product.
- Kit includes Servo Motor, Gearhead, Coupling, Amplifier, Proximity Switch, Drive Shaft, Mounting Hardware, Electrical Documentation and Cables.

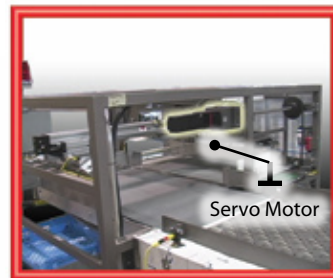
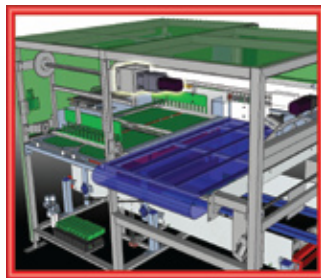

Servo Drive Disc Turner Servo Upgrade

Disc Turner Upgrade

- Replace the obsolete stepper drive with a servo drive for smoother operation and greater package configuration control.
- Kit includes Servo Motor, Gearhead, Coupling, Amplifier, Gearhead, Panel, Electrical Cableing, Control Wiring and Documentation.



Servo Pusher Slide Assembly Upgrade

▼ Pusher Slide Assembly Upgrade Kit

- Replace the obsolete Thompson Rail Assembly with a new servo drive and Macron Slide Belt Assembly resulting in smoother mechanical operation, product transfer, and adjustable compression settings for the product.
- Kit includes Pusher Assembly, Servo, Servo Drive, Carrier Chain, Mounting Hardware, Control Wiring, Electrical Documentation and Cables.

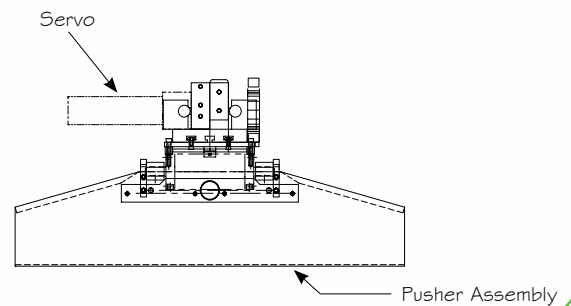
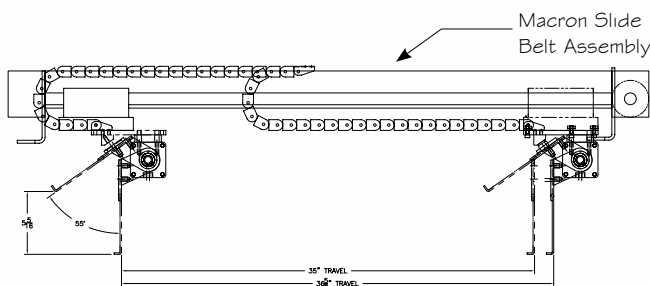

Operator Interface Upgrade

▼ Upgrade older loaders with outdated and hard to replace Cincinnati, Uticor, TCP Smart Touch, Texas Instruments to the new standard in machine interfaces with a PanelView Standard or PanelView Plus Terminal.

- Select your PanelView 1000 Standard or PanelView Plus 1250 Terminal.
- New box enclosure.
- Pre-programmed and ready to go.
- PLC Processor or Firmware upgrade may be necessary.



PLC Upgrade Kit

- ▼ Upgrade your obsolete Westinghouse PLC or to a Allen Bradley SLC 5/04 or 5/05 PLC.
- Pre-programmed and ready to install.
- Avoid costly downtime by gaining full product support with off-the-shelf parts availability and technical service support.



Note: Not all upgrades are available for all vintage Product Loaders. Contact the AMF Inside Sales Department for details.

Upgrade Kits are also available for Pulver and AMF Stackers, Unstackers and System Control Panels.

Substantially improve performance over your existing machine with a new Product Orientor Loader kit from AMF Bakery Systems!

Disc Turner Recoating

Over time the Disc Turners's surface can lose its roughness and become smooth, decreasing the performance of the machine. AMF can recoat the Disc Turner's surface to ensure it's maximum performance.

Infeed Conveyor Upgrades

Early model Pulver Loaders came with hard, flat plastic type conveyor belting. Upgrade your conveyor belting to the current Intralox Flush Grid style offered on new AMF Loaders for better infeed staging performance.

Headquarters:

2115 Laburnum Ave.
Richmond, Virginia 23227
Tel: 1-800-255-3771
or 1-804-355-7961
Fax: 1-804-342-9724
sales@amfbakery.com

Europe Office:

6 The Sidings,
Station Road, Guiseley
Leeds LS20 8BX
England
Tel: 44 (0) 1943 875703
Fax: 44 (0) 1943 871806
sales-europe@amfbakery.com

Asia Office:

Room 15-2, A-Building,
Thuniss Dev. Building,
No.11 Hui Xin East Street,
Chaoyang District
Beijing, China 100029,
P.R. China
Tel: 86-10-64823613
Fax: 86-10-64934259
sales-asia@amfbakery.com

FOR MORE INFORMATION PLEASE CALL YOUR ACCOUNT MANAGER OR

1-800-BAKERS-1

www.amfbakery.com

AMF's focus on continuous improvement may result in changes to machinery specifications without notice.