

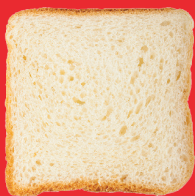

Rise Together.

# BreadFlex Divider

Small footprint extrusion divider delivers unmatched flexibility with proprietary vane-style metering pump for improved product consistency and scaling.

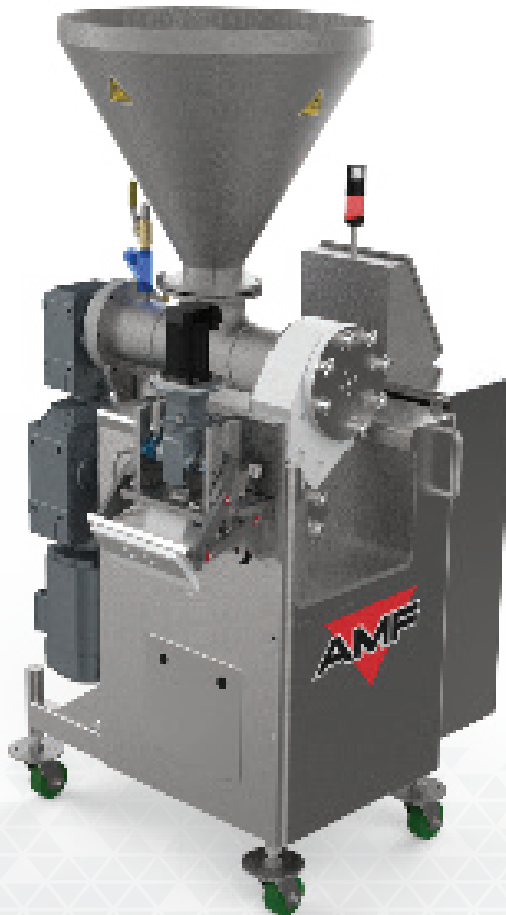

# DESIGN INNOVATIONS

As consumer demands continue to change, so must our technology. AMF's FLEX dividing technology promises the efficiency needed for the high-speed bread production of today with the flexibility to adapt to tomorrow's products. Quickly becoming the industry standard, FLEX allows bakers to make a wider variety of products on their make-up lines at a lower cost. Designed with very simple operating procedures allowing unmatched accuracy with a very small amount of operator adjustments required. Scaling is virtually automatic from the recipe management system and product quality is excellent with the low pressure dough process.

## FLEXIBILITY

Very simple changeover from one product to another, including automated port speed settings and port blockout. Variable speed auger allows maximum product flexibility.

## ACCURACY

BreadFlex offers superior scaling accuracy throughout the life of the divider. A low pressure environment controlled by a precise pressure transducer and recipe management ensure little operator adjustment is required to maintain consistency.

## SIMPLICITY

Utilizing the simplest sanitation procedures and open access design, no tools are needed for less than 15 minutes of cleanup. No divider oil is required reducing operating and sanitation costs. With 60% fewer moving parts, BreadFlex reduces overall maintenance costs.

## EFFICIENCY

With unmatched accuracy, BreadFlex keeps your line running at maximum efficiency. Proprietary vane style metering pump controls throughput without shear and 100% purge per resolution, ensuring 'first-in, first-out.'



## Flexibility Meets Efficiency

# OTHER ADVANTAGES

- ▼ Built-in low maintenance single screw dough feed system improves product consistency and scaling. Rotary design provides service life 3-4 times longer than a conventional divider with low operating noise level (< 80dB)
- ▼ Rotary motion cut-off provides a gentle slicing action
- ▼ Stainless steel, open access frame allows for easier sanitation and maintenance
- ▼ Operator interface-based recipe management system ensures consistent and repeatable automated divider set-up.
- ▼ Integrated control panel for easy installation
- ▼ Ultra low shear, vane style metering for precise linear flow control
- ▼ Interchangeable cut-off nozzles for a variety of shapes and sizes
- ▼ Feed screw and metering pump have direct coupled drives, no chains or pulleys
- ▼ UHMW cut-off knife slices cleanly, without tearing gluten strands and provides precise doughball placements at any speed from 10 to 70 pieces per minute



Direct Drive AC Sew Gearmotors

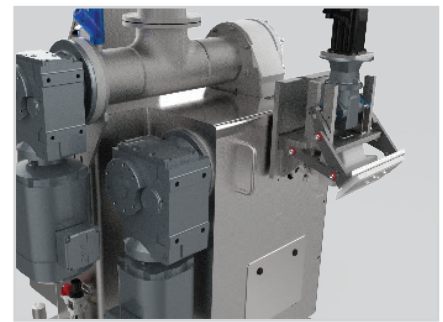

Servo Driven Cut-Off

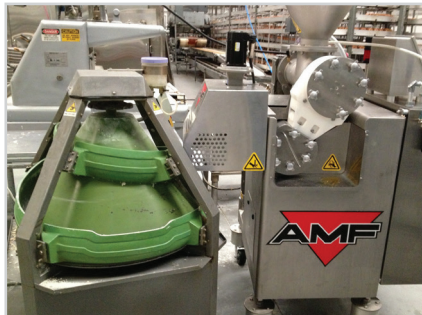

Sanitary "Uni-Body" SS Frame

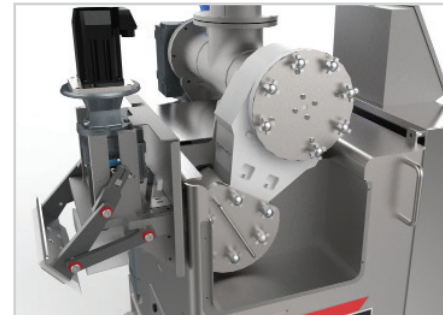

Vane Style Metering Pump

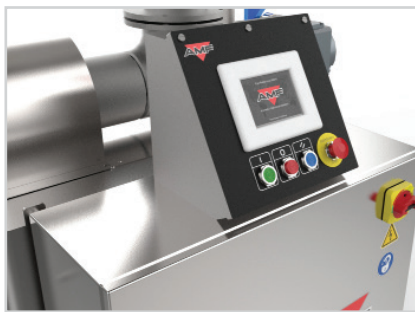

Operator Interface Panel

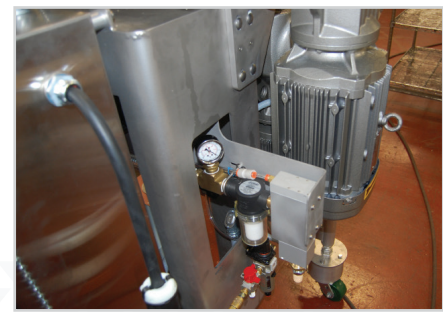

Now With Optional Hopper Screw

# SPECIFICATIONS

Model	Maximum Throughput Range	Scaling Range	Speed Range*	Approximate Shipping Dimensions	Approximate Shipping Weight
BreadFlex Divider	2,360 kg/hr. 5,202 lb./hr.	140 g to 1,000 g 5oz. to 36 oz.	10 - 70 cpm	1524 mm x 1524 mm x 2134 mm 60" x 60" x 84"	1030 kg 2,270 lb.

\* Gearmotors are sized to meet specific production requirements, therefore the divider will be geared to handle a specific range of production.

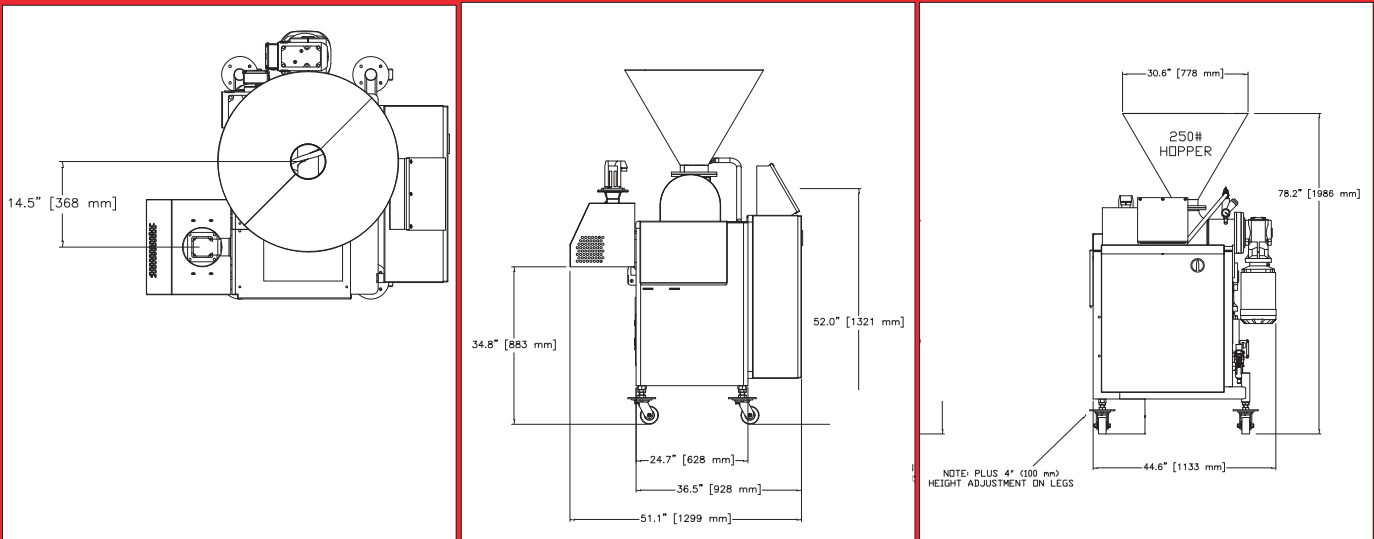

# OPTIONS

Optional belt rounder or cone rounder available.

**AMF IS A MARKEL FOOD GROUP COMPANY**



AMF's focus on continuous improvement may result in changes to machinery specifications without notice.